

Technical data sheet

Product features



Combi convection steam oven STEAMBOX gas 10x GN 2/1 automatic cleaning boiler left door

Model	SAP Code	00014905
--------------	-----------------	----------



- Steam type: Symbiotic - boiler and injection combination (patent)
- Number of GN / EN: 10
- GN / EN size in device: GN 2/1
- GN device depth: 65
- Control type: Touchscreen + buttons
- Display size: 9"
- Humidity control: MeteoSystem - regulation based on direct measurement of humidity in the chamber (patented)
- Advanced moisture adjustment: Steamtuner - 5-stage system of setting steam saturation by controlled combination of production by boiler or injection
- Delta T heat preparation: Yes
- Automatic preheating: Yes
- Multi level cooking: Drawer program - control of heat treatment for each dish separately
- Door constitution: Vented safety double glass, removable for easy cleaning

SAP Code	00014905	Type of gas	Natural Gas
Net Width [mm]	1120	Steam type	Symbiotic - boiler and injection combination (patent)
Net Depth [mm]	845	Number of GN / EN	10
Net Height [mm]	1115	GN / EN size in device	GN 2/1
Net Weight [kg]	250.00	GN device depth	65
Power electric [kW]	3.300	Control type	Touchscreen + buttons
Loading	230 V / 1N - 50 Hz	Display size	9"
Power gas [kW]	27.000		

Technical data sheet

Technical drawing



Combi convection steam oven STEAMBOX gas 10x GN 2/1 automatic cleaning boiler left door

Model

SAP Code

00014905

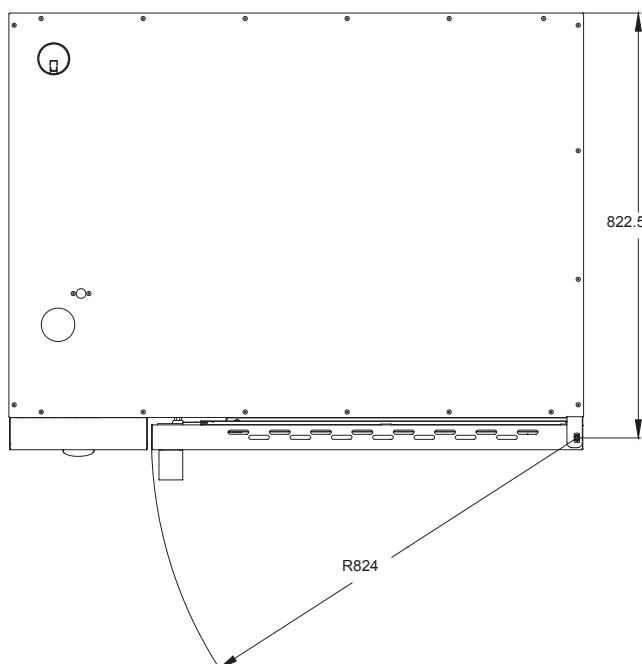
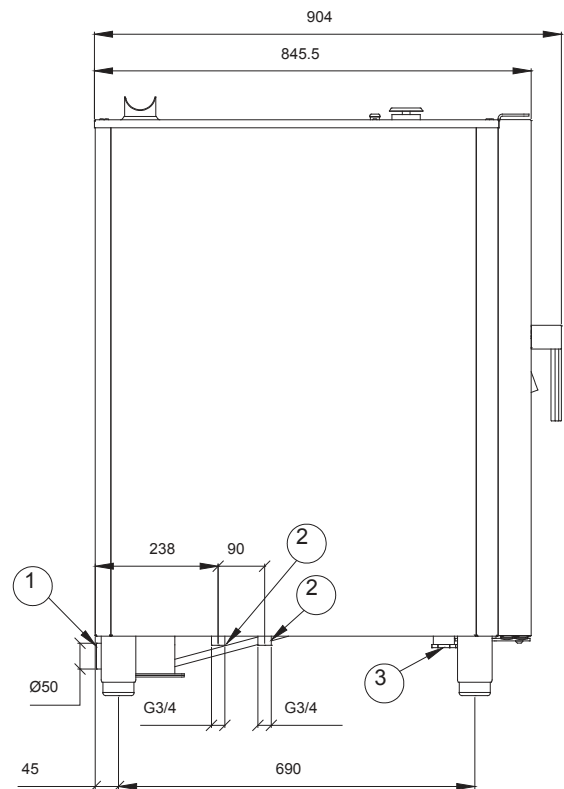
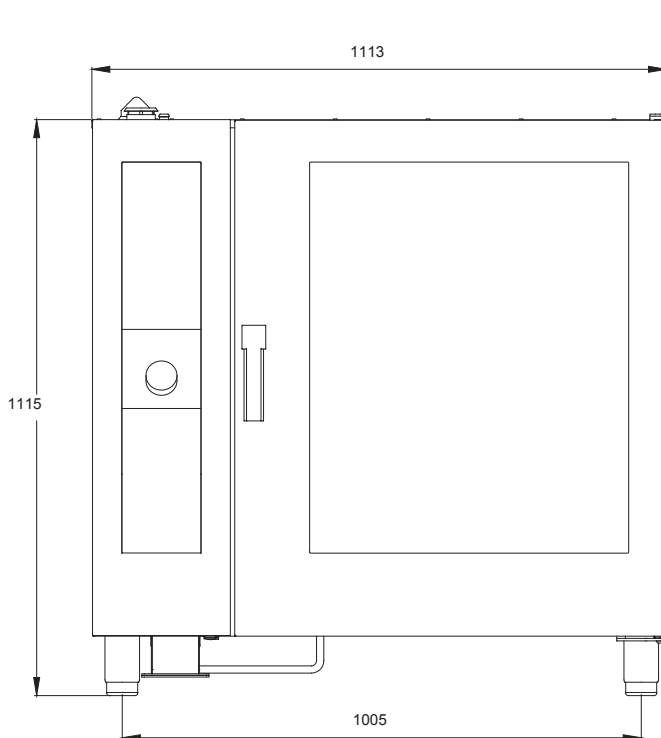

- ① DRAIN
- ② WATER INLET
- ③ POWER SUPPLY

Technical data sheet

Technical parameters



Combi convection steam oven STEAMBOX gas 10x GN 2/1 automatic cleaning boiler left door

Model

SAP Code

00014905

1. SAP Code:

00014905

2. Net Width [mm]:

1120

3. Net Depth [mm]:

845

4. Net Height [mm]:

1115

5. Net Weight [kg]:

250.00

6. Gross Width [mm]:

1320

7. Gross depth [mm]:

1130

8. Gross Height [mm]:

1240

9. Gross Weight [kg]:

260.00

10. Device type:

Combined unit

11. Power electric [kW]:

3.300

12. Loading:

230 V / 1N - 50 Hz

13. Power gas [kW]:

27.000

14. Type of gas:

Natural Gas

15. Material:

AISI 304

16. Exterior color of the device:

Stainless steel

17. Adjustable feet:

Yes

18. Humidity control:

MeteoSystem - regulation based on direct measurement of humidity in the chamber (patented)

19. Stacking availability:

Yes

20. Control type:

Touchscreen + buttons

21. Additional information:

Version with left door (hinges on the left, handle on the right)

22. Steam type:

Symbiotic - boiler and injection combination (patent)

23. Chimney for moisture extraction:

Yes

24. Delayed start:

Yes

25. Display size:

9"

26. Delta T heat preparation:

Yes

Technical data sheet

Technical parameters



Combi convection steam oven STEAMBOX gas 10x GN 2/1 automatic cleaning boiler left door

Model

SAP Code

00014905

27. Automatic preheating:

Yes

28. Automatic cooling:

Yes

29. Cold smoke-dry function:

Yes

30. Unified finishing of meals EasyService:

Yes

31. Night cooking:

Yes

32. Washing system:

Closed - efficient use of water and washing chemicals by repeated pumping

33. Detergent type:

Liquid washing detergent + liquid rinse aid/vinegar or washing tablets

34. Multi level cooking:

Drawer program - control of heat treatment for each dish separately

35. Advanced moisture adjustment:

Steamtuner - 5-stage system of setting steam saturation by controlled combination of production by boiler or injection

36. Slow cooking:

from 30 °C - the possibility of rising

37. Fan stop:

Immediate when the door is opened

38. Lighting type:

LED lighting in the doors, on both sides

39. Cavity material and shape:

AISI 304, with rounded corners for easy cleaning

40. Reversible fan:

Yes

41. Sustaine box:

Yes

42. Probe:

Yes

43. Shower:

Hand winder

44. Distance between the layers [mm]:

70

45. Smoke-dry function:

Yes

46. Interior lighting:

Yes

47. Low temperature heat treatment:

Yes

48. Number of fans:

1

49. Number of fan speeds:

6

50. Number of programs:

1000

51. USB port:

Yes, for uploading recipes and updating firmware

52. Door constitution:

Vented safety double glass, removable for easy cleaning

Technical data sheet

Technical parameters



Combi convection steam oven STEAMBOX gas 10x GN 2/1 automatic cleaning boiler left door

Model

SAP Code

00014905

53. Number of preset programs:

100

58. HACCP:

Yes

54. Number of recipe steps:

9

59. Number of GN / EN:

10

55. Minimum device temperature [°C]:

30

60. GN / EN size in device:

GN 2/1

56. Maximum device temperature [°C]:

300

61. GN device depth:

65

57. Device heating type:

Combination of steam and hot air

62. Food regeneration:

Yes